

Variable Gain Low Noise Current Amplifier

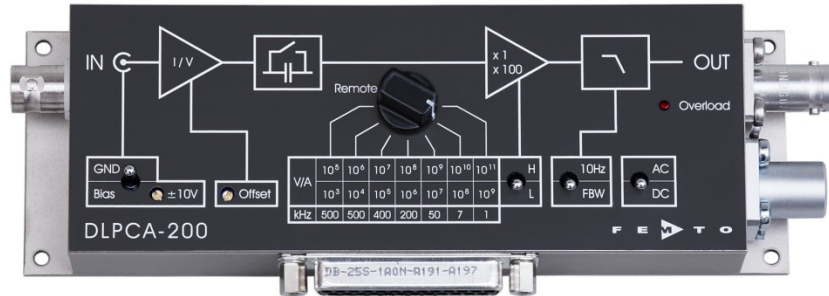

<p>Features</p>	<ul style="list-style-type: none"> • Transimpedance (gain) switchable from 1×10^3 to 1×10^{11} V/A • Bandwidth DC/1 Hz ... 500 kHz • Bandwidth switchable to DC ... 10 Hz for low noise DC measurements • Bandwidth independent of detector capacitance (up to 1 nF) • Adjustable bias voltage • Protection against ± 3 kV transients • Local and remote control
<p>Applications</p>	<ul style="list-style-type: none"> • Photodiode and photomultiplier amplifier • Scanning tunneling microscopy (STM) • Spectroscopy • Beam monitoring for particle accelerators/synchrotrons • Ionisation detectors • Preamplifier for lock-ins, A/D converters, etc.
<p>Block Diagram</p>	<p style="text-align: right;">BS01-0141-10</p>

Variable Gain Low Noise Current Amplifier

Specifications	Test conditions $V_s = \pm 15\text{ V}$, $T_A = 25\text{ }^\circ\text{C}$, load impedance = 1 M Ω																																																																																																																																																																
Gain	Transimpedance Gain accuracy Gain drift $1 \times 10^3 \dots 1 \times 10^{11}\text{ V/A}$ $\pm 1\%$ see table below																																																																																																																																																																
Frequency Response	Lower cut-off frequency Upper cut-off frequency (-3 dB) Gain flatness DC / 1 Hz up to 500 kHz (see table below), switchable to 10 Hz $\pm 0.1\text{ dB}$																																																																																																																																																																
Input	Equ. input noise current Equ. input noise voltage Input offset current drift Input bias current Max. input current Input offset compensation see table below 4 nV/ $\sqrt{\text{Hz}}$ (@ 1 kHz) see table below 1 pA typ. (max. 3 pA) see table below (value for linear amplification) adjustable by offset potentiometer and external control voltage; max. range see table below																																																																																																																																																																
Performance depending on Gain Setting	<table border="1" style="width: 100%; border-collapse: collapse;"> <thead> <tr> <th style="text-align: left;">Gain setting (low noise) (V/A)</th> <th>10³</th> <th>10⁴</th> <th>10⁵</th> <th>10⁶</th> <th>10⁷</th> <th>10⁸</th> <th>10⁹</th> </tr> </thead> <tbody> <tr> <td>Upper cut-off frequency (-3 dB)</td> <td>500 kHz</td> <td>500 kHz</td> <td>400 kHz</td> <td>200 kHz</td> <td>50 kHz</td> <td>7 kHz</td> <td>1.1 kHz</td> </tr> <tr> <td>Rise/fall time (10 % - 90 %)</td> <td>700 ns</td> <td>700 ns</td> <td>900 ns</td> <td>1.8 μs</td> <td>7 μs</td> <td>50 μs</td> <td>300 μs</td> </tr> <tr> <td>Input noise current density ($\sqrt{\text{Hz}}$) measured at</td> <td>20 pA</td> <td>2.3 pA</td> <td>450 fA</td> <td>130 fA</td> <td>43 fA</td> <td>13 fA</td> <td>4.3 fA</td> </tr> <tr> <td>Integr. input noise current (rms)*</td> <td>21 nA</td> <td>2.4 nA</td> <td>500 pA</td> <td>130 pA</td> <td>41 pA</td> <td>5.8 pA</td> <td>0.8 pA</td> </tr> <tr> <td>Offset current drift ($^\circ\text{C}$)</td> <td>30 nA</td> <td>3 nA</td> <td>0.3 nA</td> <td>30 pA</td> <td>3 pA</td> <td>0.3 pA</td> <td>0.1 pA</td> </tr> <tr> <td>Gain drift ($^\circ\text{C}$)</td> <td>0.008%</td> <td>0.008%</td> <td>0.008%</td> <td>0.01%</td> <td>0.01%</td> <td>0.01%</td> <td>0.02%</td> </tr> <tr> <td>Max. input current (\pm)</td> <td>10 mA</td> <td>1 mA</td> <td>0.1 mA</td> <td>10 μA</td> <td>1 μA</td> <td>0.1 μA</td> <td>10 nA</td> </tr> <tr> <td>Input offset compensation (\pm)</td> <td>100 μA</td> <td>10 μA</td> <td>1 μA</td> <td>0.1 μA</td> <td>10 nA</td> <td>1 nA</td> <td>0.1 nA</td> </tr> <tr> <td>DC input impedance (\parallel 5 pF)</td> <td>50 Ω</td> <td>50 Ω</td> <td>50 Ω</td> <td>60 Ω</td> <td>150 Ω</td> <td>1 kΩ</td> <td>10 kΩ</td> </tr> <tr> <th style="text-align: left;">Gain setting (high speed) (V/A)</th> <th>10⁵</th> <th>10⁶</th> <th>10⁷</th> <th>10⁸</th> <th>10⁹</th> <th>10¹⁰</th> <th>10¹¹</th> </tr> <tr> <td>Upper cut-off frequency (-3 dB)</td> <td>500 kHz</td> <td>500 kHz</td> <td>400 kHz</td> <td>200 kHz</td> <td>50 kHz</td> <td>7 kHz</td> <td>1.1 kHz</td> </tr> <tr> <td>Rise/fall time (10 % - 90 %)</td> <td>700 ns</td> <td>700 ns</td> <td>900 ns</td> <td>1.8 μs</td> <td>7 μs</td> <td>50 μs</td> <td>300 μs</td> </tr> <tr> <td>Input noise current density ($\sqrt{\text{Hz}}$) measured at</td> <td>13 pA</td> <td>1.8 pA</td> <td>440 fA</td> <td>130 fA</td> <td>43 fA</td> <td>13 fA</td> <td>4.3 fA</td> </tr> <tr> <td>Integr. input noise current (rms)*</td> <td>12 nA</td> <td>1.8 nA</td> <td>450 pA</td> <td>120 pA</td> <td>37 pA</td> <td>5.3 pA</td> <td>0.8 pA</td> </tr> <tr> <td>Offset current drift ($^\circ\text{C}$)</td> <td>30 nA</td> <td>3 nA</td> <td>0.3 nA</td> <td>30 pA</td> <td>3 pA</td> <td>0.3 pA</td> <td>0.1 pA</td> </tr> <tr> <td>Gain drift ($^\circ\text{C}$)</td> <td>0.008%</td> <td>0.008%</td> <td>0.008%</td> <td>0.01%</td> <td>0.01%</td> <td>0.01%</td> <td>0.02%</td> </tr> <tr> <td>Max. input current (\pm)</td> <td>100 μA</td> <td>10 μA</td> <td>1 μA</td> <td>0.1 μA</td> <td>10 nA</td> <td>1 nA</td> <td>0.1 nA</td> </tr> <tr> <td>Input offset compensation (\pm)</td> <td>100 μA</td> <td>10 μA</td> <td>1 μA</td> <td>0.1 μA</td> <td>10 nA</td> <td>1 nA</td> <td>0.1 nA</td> </tr> <tr> <td>DC input impedance (\parallel 5 pF)</td> <td>50 Ω</td> <td>50 Ω</td> <td>50 Ω</td> <td>60 Ω</td> <td>150 Ω</td> <td>1 kΩ</td> <td>10 kΩ</td> </tr> </tbody> </table> <p>* The integrated input noise is measured with an open but shielded amplifier input in the full bandwidth ("FBW") setting. The input referred peak-peak noise can be calculated from the rms noise as follows: $I_{pp} = I_{RMS} \times 6$ The output noise is given by: $U_{pp} = I_{pp} \times \text{gain}$ </p>	Gain setting (low noise) (V/A)	10 ³	10 ⁴	10 ⁵	10 ⁶	10 ⁷	10 ⁸	10 ⁹	Upper cut-off frequency (-3 dB)	500 kHz	500 kHz	400 kHz	200 kHz	50 kHz	7 kHz	1.1 kHz	Rise/fall time (10 % - 90 %)	700 ns	700 ns	900 ns	1.8 μs	7 μs	50 μs	300 μs	Input noise current density ($\sqrt{\text{Hz}}$) measured at	20 pA	2.3 pA	450 fA	130 fA	43 fA	13 fA	4.3 fA	Integr. input noise current (rms)*	21 nA	2.4 nA	500 pA	130 pA	41 pA	5.8 pA	0.8 pA	Offset current drift ($^\circ\text{C}$)	30 nA	3 nA	0.3 nA	30 pA	3 pA	0.3 pA	0.1 pA	Gain drift ($^\circ\text{C}$)	0.008%	0.008%	0.008%	0.01%	0.01%	0.01%	0.02%	Max. input current (\pm)	10 mA	1 mA	0.1 mA	10 μA	1 μA	0.1 μA	10 nA	Input offset compensation (\pm)	100 μA	10 μA	1 μA	0.1 μA	10 nA	1 nA	0.1 nA	DC input impedance (\parallel 5 pF)	50 Ω	50 Ω	50 Ω	60 Ω	150 Ω	1 k Ω	10 k Ω	Gain setting (high speed) (V/A)	10 ⁵	10 ⁶	10 ⁷	10 ⁸	10 ⁹	10 ¹⁰	10 ¹¹	Upper cut-off frequency (-3 dB)	500 kHz	500 kHz	400 kHz	200 kHz	50 kHz	7 kHz	1.1 kHz	Rise/fall time (10 % - 90 %)	700 ns	700 ns	900 ns	1.8 μs	7 μs	50 μs	300 μs	Input noise current density ($\sqrt{\text{Hz}}$) measured at	13 pA	1.8 pA	440 fA	130 fA	43 fA	13 fA	4.3 fA	Integr. input noise current (rms)*	12 nA	1.8 nA	450 pA	120 pA	37 pA	5.3 pA	0.8 pA	Offset current drift ($^\circ\text{C}$)	30 nA	3 nA	0.3 nA	30 pA	3 pA	0.3 pA	0.1 pA	Gain drift ($^\circ\text{C}$)	0.008%	0.008%	0.008%	0.01%	0.01%	0.01%	0.02%	Max. input current (\pm)	100 μA	10 μA	1 μA	0.1 μA	10 nA	1 nA	0.1 nA	Input offset compensation (\pm)	100 μA	10 μA	1 μA	0.1 μA	10 nA	1 nA	0.1 nA	DC input impedance (\parallel 5 pF)	50 Ω	50 Ω	50 Ω	60 Ω	150 Ω	1 k Ω	10 k Ω
Gain setting (low noise) (V/A)	10 ³	10 ⁴	10 ⁵	10 ⁶	10 ⁷	10 ⁸	10 ⁹																																																																																																																																																										
Upper cut-off frequency (-3 dB)	500 kHz	500 kHz	400 kHz	200 kHz	50 kHz	7 kHz	1.1 kHz																																																																																																																																																										
Rise/fall time (10 % - 90 %)	700 ns	700 ns	900 ns	1.8 μs	7 μs	50 μs	300 μs																																																																																																																																																										
Input noise current density ($\sqrt{\text{Hz}}$) measured at	20 pA	2.3 pA	450 fA	130 fA	43 fA	13 fA	4.3 fA																																																																																																																																																										
Integr. input noise current (rms)*	21 nA	2.4 nA	500 pA	130 pA	41 pA	5.8 pA	0.8 pA																																																																																																																																																										
Offset current drift ($^\circ\text{C}$)	30 nA	3 nA	0.3 nA	30 pA	3 pA	0.3 pA	0.1 pA																																																																																																																																																										
Gain drift ($^\circ\text{C}$)	0.008%	0.008%	0.008%	0.01%	0.01%	0.01%	0.02%																																																																																																																																																										
Max. input current (\pm)	10 mA	1 mA	0.1 mA	10 μA	1 μA	0.1 μA	10 nA																																																																																																																																																										
Input offset compensation (\pm)	100 μA	10 μA	1 μA	0.1 μA	10 nA	1 nA	0.1 nA																																																																																																																																																										
DC input impedance (\parallel 5 pF)	50 Ω	50 Ω	50 Ω	60 Ω	150 Ω	1 k Ω	10 k Ω																																																																																																																																																										
Gain setting (high speed) (V/A)	10 ⁵	10 ⁶	10 ⁷	10 ⁸	10 ⁹	10 ¹⁰	10 ¹¹																																																																																																																																																										
Upper cut-off frequency (-3 dB)	500 kHz	500 kHz	400 kHz	200 kHz	50 kHz	7 kHz	1.1 kHz																																																																																																																																																										
Rise/fall time (10 % - 90 %)	700 ns	700 ns	900 ns	1.8 μs	7 μs	50 μs	300 μs																																																																																																																																																										
Input noise current density ($\sqrt{\text{Hz}}$) measured at	13 pA	1.8 pA	440 fA	130 fA	43 fA	13 fA	4.3 fA																																																																																																																																																										
Integr. input noise current (rms)*	12 nA	1.8 nA	450 pA	120 pA	37 pA	5.3 pA	0.8 pA																																																																																																																																																										
Offset current drift ($^\circ\text{C}$)	30 nA	3 nA	0.3 nA	30 pA	3 pA	0.3 pA	0.1 pA																																																																																																																																																										
Gain drift ($^\circ\text{C}$)	0.008%	0.008%	0.008%	0.01%	0.01%	0.01%	0.02%																																																																																																																																																										
Max. input current (\pm)	100 μA	10 μA	1 μA	0.1 μA	10 nA	1 nA	0.1 nA																																																																																																																																																										
Input offset compensation (\pm)	100 μA	10 μA	1 μA	0.1 μA	10 nA	1 nA	0.1 nA																																																																																																																																																										
DC input impedance (\parallel 5 pF)	50 Ω	50 Ω	50 Ω	60 Ω	150 Ω	1 k Ω	10 k Ω																																																																																																																																																										
Output	Output voltage Output impedance Max. output current $\pm 10\text{ V}$ (@ $\geq 100\text{ k}\Omega$ load) 50 Ω (terminate with $\geq 100\text{ k}\Omega$ load for best performance) $\pm 30\text{ mA}$																																																																																																																																																																
Detector Bias	Bias voltage range $\pm 10\text{ V}$, max. 22 mA (bias voltage connected to shield of BNC input socket, adjustable by potentiometer, switchable to GND)																																																																																																																																																																

Variable Gain Low Noise Current Amplifier

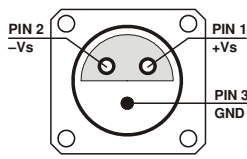
Indicator LED	Function	overload
Digital Control	Control input voltage range	LOW bit: -0.8 V ... +1.2 V, HIGH bit: 2.3 V ... +12 V
	Control input current	0 mA @ 0 V, 1.5 mA @ +5 V, 4.5 mA @ +12 V
	Overload output	non active: <0.4 V @ 0 ... -1 mA active: typ. 5 ... 5.1 V @ 0 ... 2 mA
Ext. Offset Control	Control voltage range	±10 V
	Offset control input impedance	20 kΩ
Power Supply	Supply voltage	±15 V
	Supply current	+120 / -80 mA typ. (depends on operating conditions, recommended power supply capability min. ±200 mA)
	Stabilized power supply output	±12 V, max. ±50 mA, +5V, max. 30 mA
Case	Weight	320 g (0.74 lb.)
	Material	AlMg4.5Mn, nickel-plated
Temperature Range	Storage temperature	-40 °C ... +100 °C
	Operating temperature	0 °C ... +60 °C
Absolute Maximum Ratings	Signal input voltage	-16 V / +12 V
	Signal input current (rms)	35 mA
	Transient input voltage	±3 kV (out of 200 pF source)
	Control input voltage	-5 V / +16 V
	Power supply voltage	±20 V
Connectors	Input	BNC, isolated, jack (female)
	Output	BNC, jack (female)
	Detector bias output	shield of input BNC
	Power supply	Lemo® series 1S, 3-pin fixed socket (mating plug type: FFA.1S.303.CLAC52)
		Pin 1: +15V Pin 2: -15V Pin 3: GND
		
	Control port	Sub-D 25-pin, female, qual. class 2
		Pin 1: +12 V (stabilized power supply output)
		Pin 2: -12 V (stabilized power supply output)
		Pin 3: AGND (analog ground)
		Pin 4: +5 V (stabilized power supply output)
		Pin 5: digital output: overload (referred to pin 3)
		Pin 6: signal output (connected to BNC)
		Pin 7: NC
		Pin 8: input offset control voltage
		Pin 9: DGND (ground for digital control pins 10 - 14)
		Pin 10: digital control input: gain, LSB
		Pin 11: digital control input: gain
		Pin 12: digital control input: gain, MSB
		Pin 13: digital control input: AC/DC
		Pin 14: digital control input: high speed / low noise
		Pin 15 - 25: NC

Variable Gain Low Noise Current Amplifier

Remote Control Operation

General

Remote control input bits are opto-isolated and connected by logical OR function to local switch settings. For remote control set the corresponding local switches to "Remote", "AC" and "H" (High speed) and select the wanted setting via a bit code at the corresponding digital inputs. Mixed operation, e.g. local gain setting and remote controlled AC/DC setting, is also possible.

Switch settings "FBW / 10 Hz" and "Bias / GND" are not remote controllable.

Gain setting

Low noise Pin 14=HIGH Gain (V/A)	High speed Pin 14=LOW Gain (V/A)	Pin 12 MSB	Pin 11	Pin 10 LSB
10^3	10^5	LOW	LOW	LOW
10^4	10^6	LOW	LOW	HIGH
10^5	10^7	LOW	HIGH	LOW
10^6	10^8	LOW	HIGH	HIGH
10^7	10^9	HIGH	LOW	LOW
10^8	10^{10}	HIGH	LOW	HIGH
10^9	10^{11}	HIGH	HIGH	LOW

Gain settling time

<150 ms

AC/DC setting

Coupling	Pin 13
AC	LOW
DC	HIGH

Application Diagram

Photo detector biasing

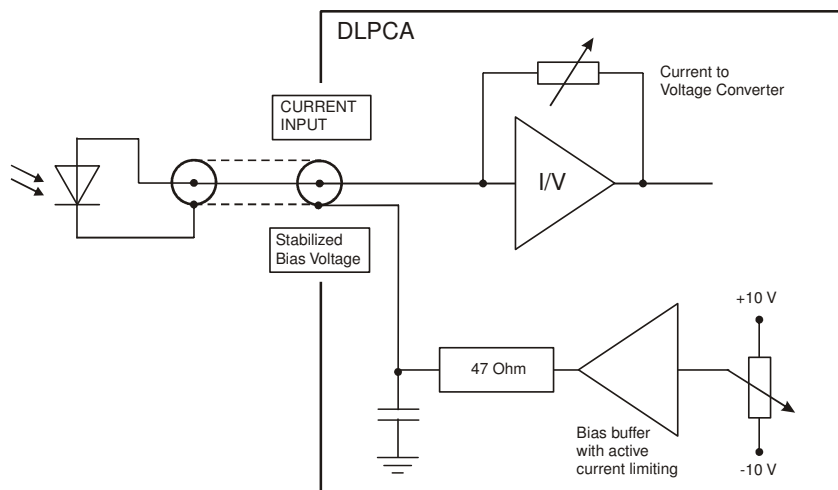

AZ01-0140-1

Variable Gain Low Noise Current Amplifier

Dimensions

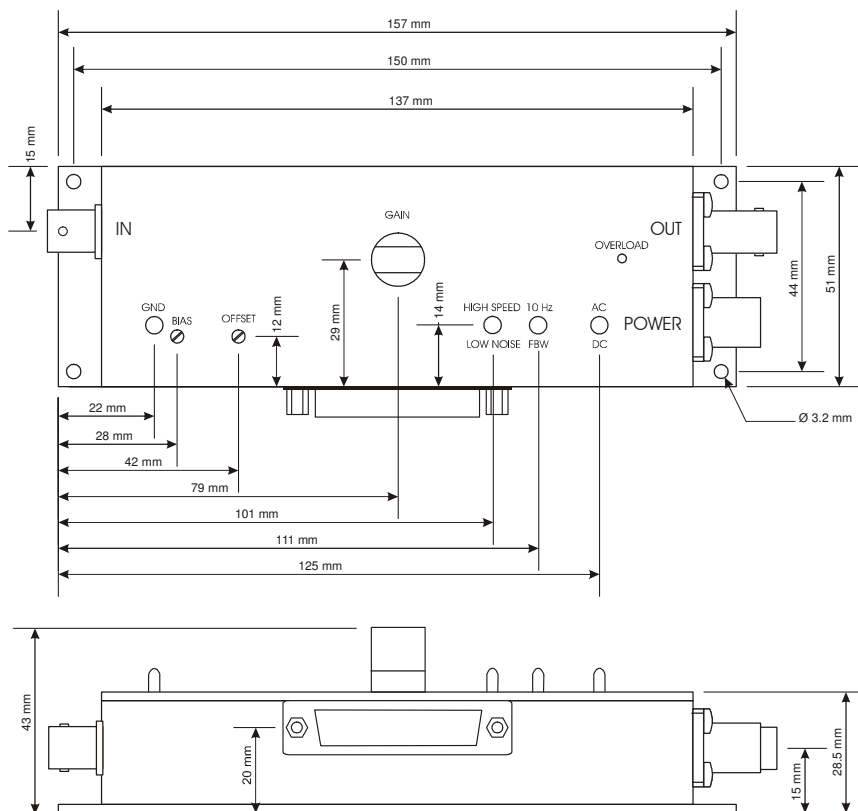

FEMTO Messtechnik GmbH
Klosterstr. 64
10179 Berlin · Germany
Phone: +49 30 280 4711-0
Fax: +49 30 280 4711-11
Email: info@femto.de
www.femto.de

Specifications are subject to change without notice. Information provided herein is believed to be accurate and reliable. However, no responsibility is assumed by FEMTO Messtechnik GmbH for its use, nor for any infringement of patents or other rights of third parties which may result from its use. No license is granted by implication or otherwise under any patent or patent rights of FEMTO Messtechnik GmbH. Product names mentioned may also be trademarks used here for identification purposes only.

© by FEMTO Messtechnik GmbH · Printed in Germany